



**COUNTY OF ORANGE**  
**RESOURCES & DEVELOPMENT MANAGEMENT DEPARTMENT**

*Bryan Speegle, Director*  
300 N. Flower Street  
Santa Ana, CA  
P.O. Box 4048  
Santa Ana, CA 92702-4048  
Telephone: (714) 834-2300  
Fax: (714) 834-5188

**DATE:** MAY - 1 2007  
**TO:** RDMD Standard Plan (2006 Edition) Holders  
**FROM:** Ignacio G. Ochoa,  
Director Public Works/Chief Engineer  
**SUBJECT:** Addendum No. 1 to RDMD Standard Plans, 2006 Edition

In accordance with Orange County Board of Supervisors Resolution 07-048 Addendum No. 1 to RDMD Standard Plans, 2006 Edition, includes the following revisions to the Standard Plans:

Revisions:

<u>Standard Plan #</u>	<u>Title</u>
1100	Principal Highway Typical Sections
1102	Major Highway Bridge Sections
1109	Rural Local Street Typical Section
1110	Rural Local Street Typical Section
1302	Inlet Type II
1805	Special Provisions – Asphalt Concrete
1806	Special Provisions – Earthwork

  
Ignacio G. Ochoa

Attachments

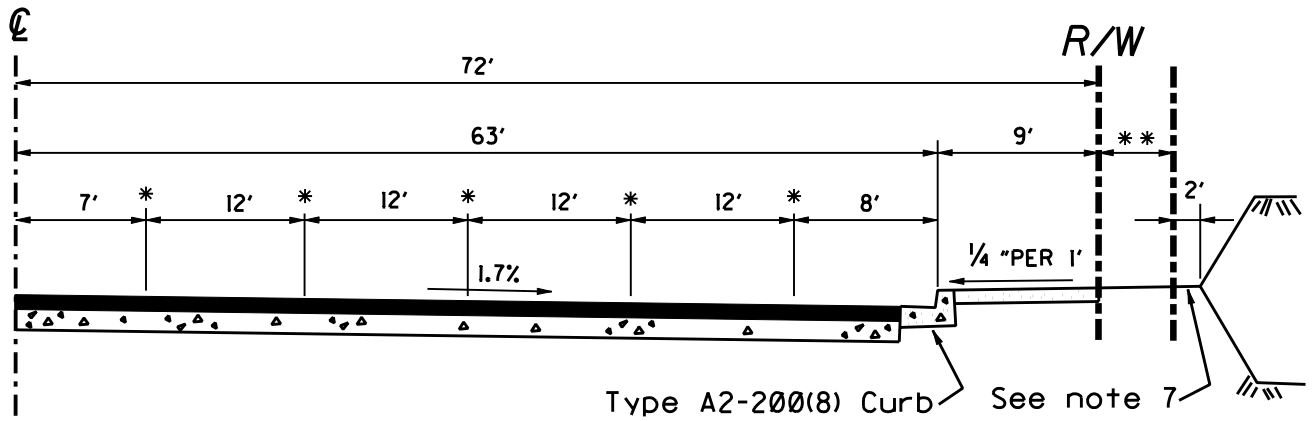

SECTIONS  
SYMMETRICAL  
ABOUT  $\mathcal{C}$

STANDARD SECTION

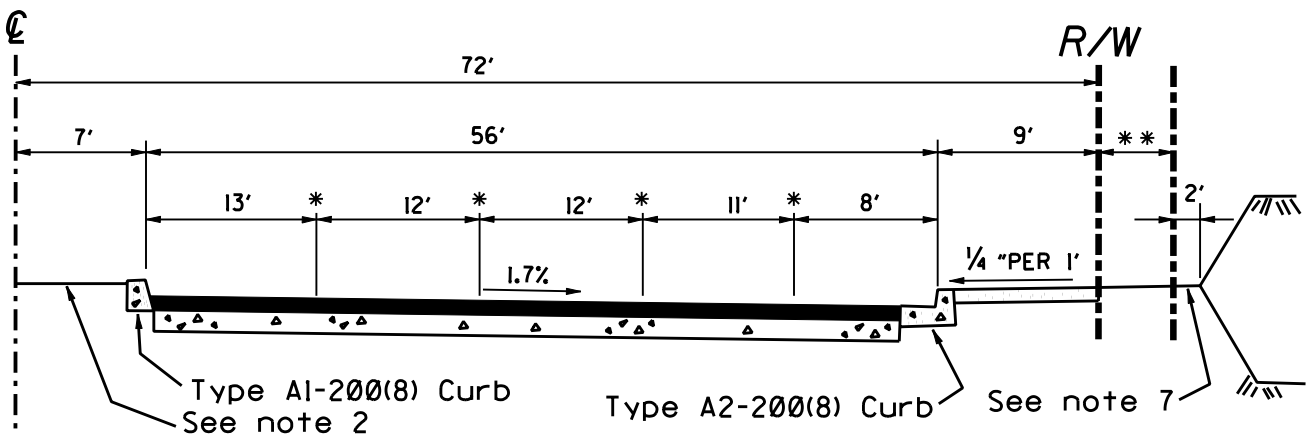

CURBED MEDIAN ALTERNATE

- \* Longitudinal joint for finish course A.C.
- \* \* Additional right of way may be required when a principal highway coincides with an adopted route for an additional public facility (i.e., pedestrian, bicycle, or equestrian trail), or for a scenic highway.

ORANGE COUNTY RESOURCES & DEVELOPMENT MANAGEMENT DEPARTMENT

Approved

*H. I. Nakasone*  
H. I. Nakasone, Chief Engineer

Adopted: Res. 96-546 Revised: Res. 06-010; 07-048

STD. PLAN

1100

PRINCIPAL HIGHWAY TYPICAL SECTIONS

SHT. 1 OF 3

**NOTES:**

1. The Standard Section shall be used except as noted below. The Curbed Median Alternate may be acceptable under any of the following conditions and subject to approval of the Engineer.
  - A. When it fills a gap on a stretch of roadway already built in adjacent areas with curbed median.
  - B. When it is a short section near intersection for delineation and/or placing traffic control devices.
  - C. When necessary to control turn movements and access on heavily traveled arterials with commercial frontage and multiple driveways.
  - D. When it is to be landscaped.
2. If the Curbed Median Alternative is used, the following applies:
  - A. See Standard Plan III4 for Landscaped Median Detail.
  - B. See Standard Plan I20-I-0C for Type A1-200(8) Curb.
  - C. To be paved with 2" A.C./approved soil sterilant unless landscaping or other paving is approved by the Engineer.
  - D. Landscaped medians shall not be maintained with road funds; a method of funding maintenance shall be established prior to approval of street improvement plans.
3. Design speed shall be at least 60 miles per hour.
4. Thickness of pavement and base to be determined by the Engineer.
5. See Standard Plan I20-I-0C for Type A2-200(8) Curb.
6. See Standard Plan I205 for Sidewalk Details.
7. Distance shown is minimum from right of way to hinge point.
8. Minimum street flow line grade shall be 1.0%, reverse grade vertical curves excepted.

ORANGE COUNTY RESOURCES & DEVELOPMENT MANAGEMENT DEPARTMENT

Approved

  
H. I. Nakasone, Chief Engineer

Adopted: Res. 96-546 Revised: Res. 06-010; 07-048

STD. PLAN

1100

SHT. 2 OF 3

PRINCIPAL HIGHWAY TYPICAL SECTIONS

# TYPICAL BRIDGE SECTIONS

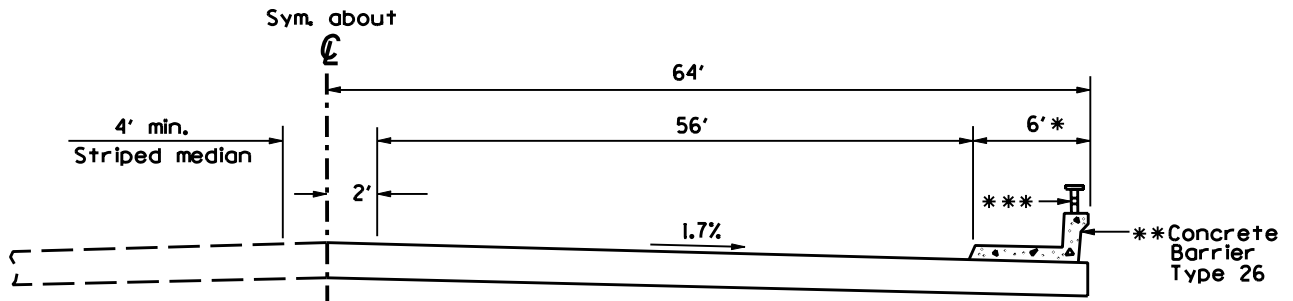

## STANDARD SECTION

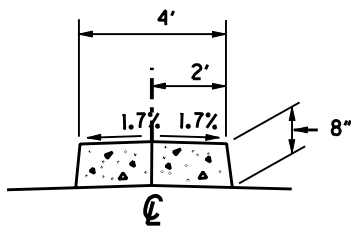

## CURBED MEDIAN ALTERNATE

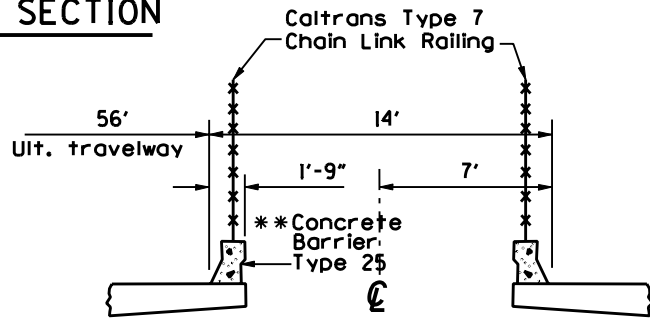

## OPEN MEDIAN ALTERNATE

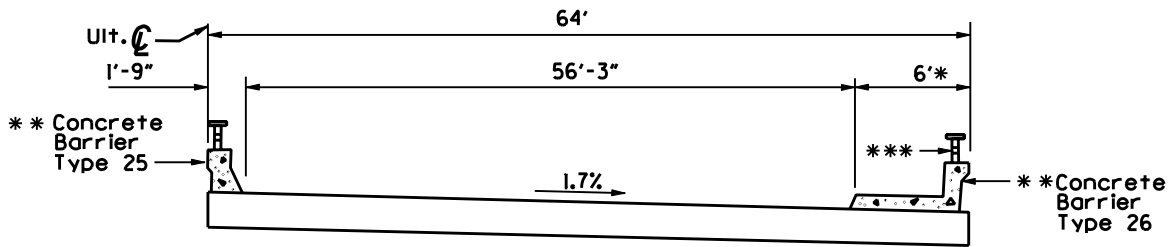

## (INITIAL PHASE)

- \* Raised sidewalk to be provided when warranted
- \*\* See Caltrans Standard Plans
- \*\*\* Caltrans Type 7 Chain Link Railing required in lieu of Tubular Hand Railing when structure spans over a public roadway.

### NOTES:

1. Ultimate bridge typical sections to be approved by the Engineer.
2. Bridge type to be approved by the Engineer.
3. Median width subject to variation depending on intersection proximity.
4. Curbed median or open median alternate to be used only when approaching highway has a raised median also.

ORANGE COUNTY RESOURCES & DEVELOPMENT MANAGEMENT DEPARTMENT

Approved

*H. I. Nakasone*  
H. I. Nakasone, Chief Engineer

Adopted: Res. 96-546 Revised: Res. 06-010; 07-048

STD. PLAN

1100

PRINCIPAL HIGHWAY TYPICAL SECTIONS

SHT. 3 OF 3

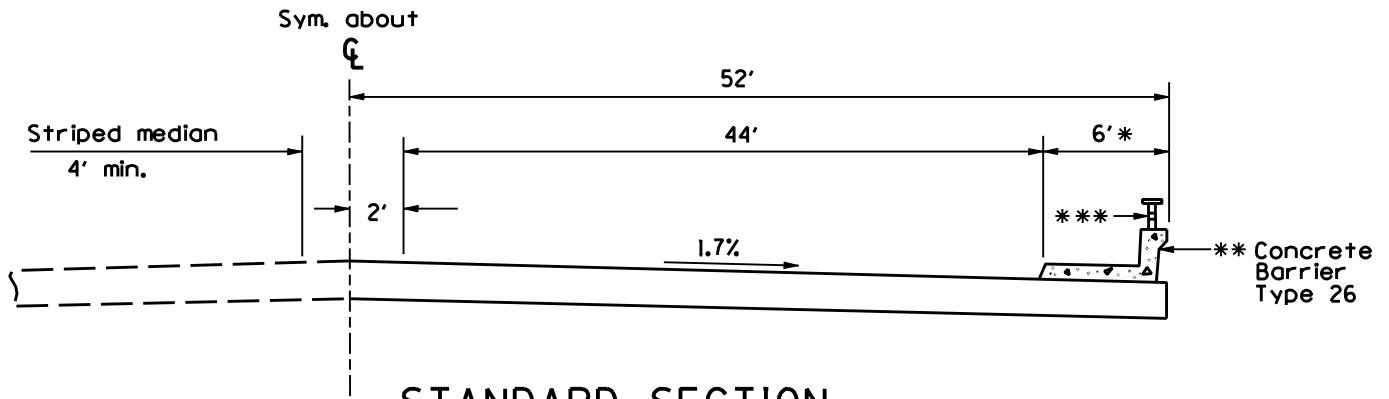

**STANDARD SECTION**

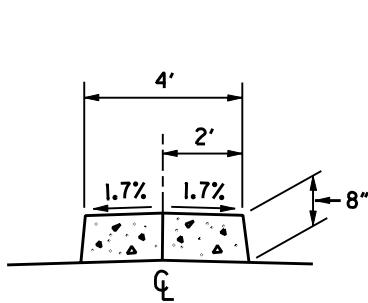

**CURBED MEDIAN ALTERNATE**

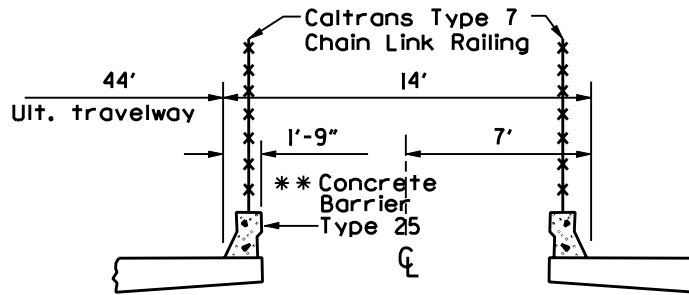

**OPEN MEDIAN ALTERNATE**

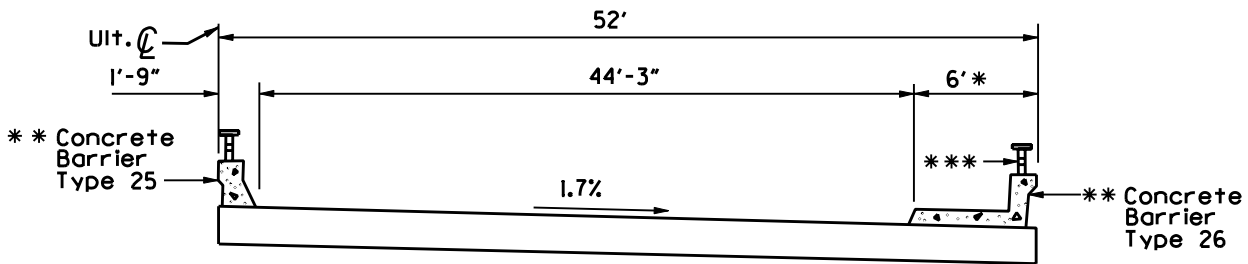

**2 LANES (INITIAL PHASE)**

- \* Raised sidewalk to be provided when warranted
- \*\* See Caltrans Standard Plans
- \*\*\* Caltrans Type 7 Chain Link Railing required in lieu of Tubular Hand Railing when structure spans over a public roadway.

**NOTES:**

1. Ultimate bridge typical sections to be approved by the Engineer.
2. Bridge type to be approved by the Engineer.
3. Median width subject to variation depending on intersection proximity.
4. Curbed median or open median alternate to be used only when approaching highway has a raised median also.

ORANGE COUNTY RESOURCES & DEVELOPMENT MANAGEMENT DEPARTMENT

Approved

H. I. Nakasone, Chief Engineer

Adopted: Res. 77-92 Revised: Res. 83-1442; 85-339; 06-010; 07-048

STD. PLAN

1102

MAJOR HIGHWAY BRIDGE SECTIONS

SHT. 1 OF 1

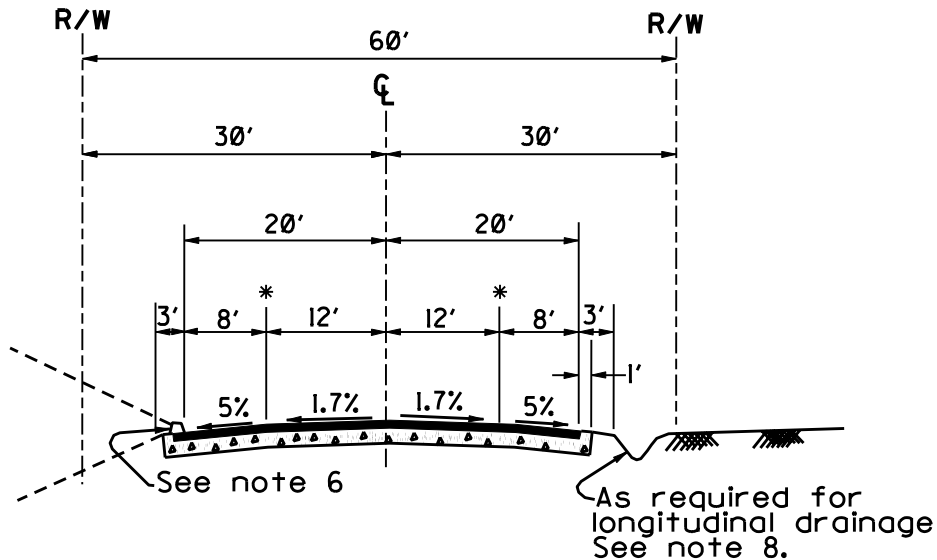

**NOTES:**

1. Std. Plan 1109 applies only to approved areas.
2. A.D.T. over 1200.
3. Additional R/W may be required where trail is adopted or established.
4. Location of improvements within the R/W may vary due to physical constraints (trees, drainage), to provide trails, etc.
5. Paved shoulder to be used for emergency parking, pedestrians, & bicycles.
6. Where roadside conditions dictate, A.C. dikes per Standard Plan 120-1-0C may be required to control drainage.
7. Required pavement structural section to be determined by the Engineer.
8. A storm drain shall be constructed when longitudinal flow exceeds capacity of the maximum size ditch which can be constructed wholly within the street right of way.
9. Minimum street flow line grade shall be 1%, reverse grade vertical curves excepted.

\* Longitudinal joint for finish course A.C.

ORANGE COUNTY RESOURCES & DEVELOPMENT MANAGEMENT DEPARTMENT

Approved

*H. I. Nakasone*  
H. I. Nakasone, Chief Engineer

Adopted: Res. 77-92

Revised: Res. 79-1725; 83-1442; 86-1141; 88-1341; 06-010; 07-048

STD. PLAN

1109

RURAL LOCAL STREET TYPICAL SECTION

SHT. 1 OF 1

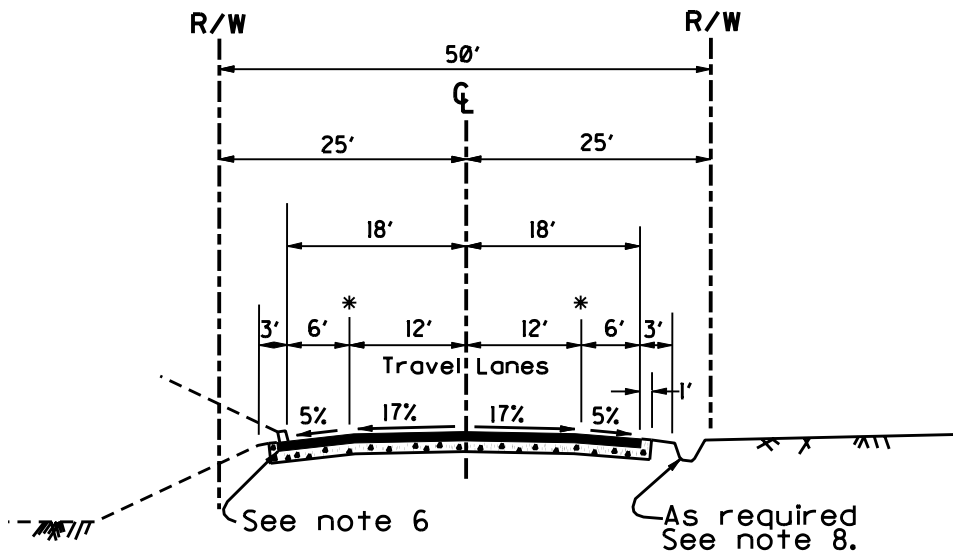

### NOTES:

1. Std. Plan 1110 applies only to approved areas.
2. A.D.T. less than 1200.
3. Additional R/W may be required where trail is adopted or established.
4. Location of improvements within the R/W may vary due to physical constraints (tress, drainage), to provide trails, etc.
5. Paved shoulder to be used for emergency parking, pedestrians, & bicycles.
6. Where roadside conditions dictate, A.C. dikes per Standard Plan 120-1-0C may be required to control drainage.
7. Required pavement structural section to be determined by the Engineer.
8. A storm drain shall be constructed when longitudinal flow exceeds capacity of the maximum size ditch which can be constructed wholly within the street right of way.
9. Minimum street flow line grade shall be 1.0%, reverse grade vertical curves excepted.

\* Longitudinal joint for finish course A.C.

ORANGE COUNTY RESOURCES & DEVELOPMENT MANAGEMENT DEPARTMENT

Approved

*H. I. Nakasone*  
H. I. Nakasone, Chief Engineer

Adopted: Res. 77-92

Revised: Res. 79-1725; 83-1442; 86-1411; 88-1341; 06-010; 07-048

STD. PLAN

1110

RURAL LOCAL STREET TYPICAL SECTION

SHT. 1 OF 1

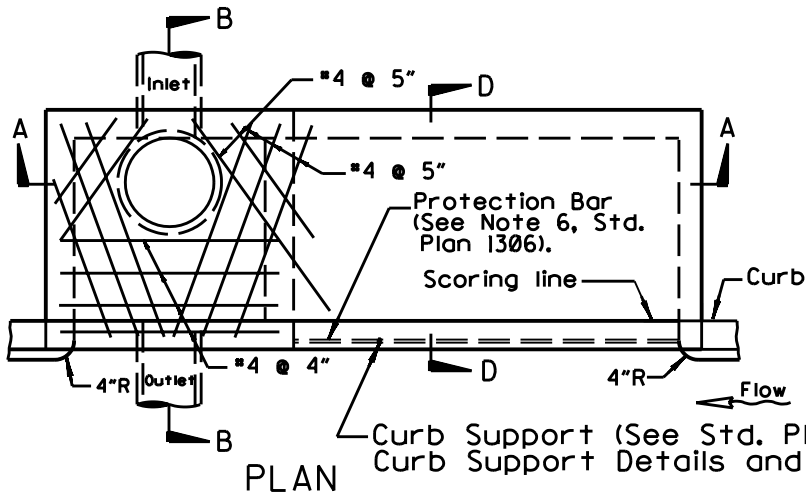

PLAN

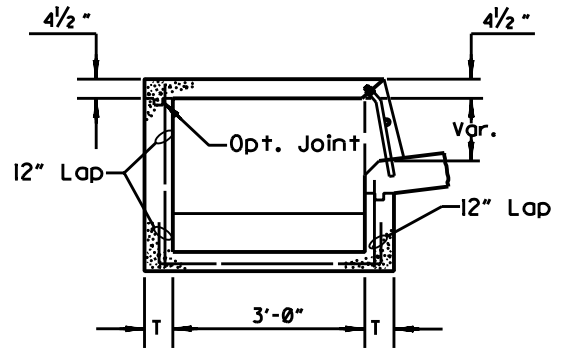

SECTION D - D

Curb Support (See Std. Plan 1306).  
Curb Support Details and Note 4.

Alhambra Foundry A-1531-B,  
Apex Steel Corp. X110B or  
equal with approved locking  
devices. See Std.  
Plan 312-2-0C.

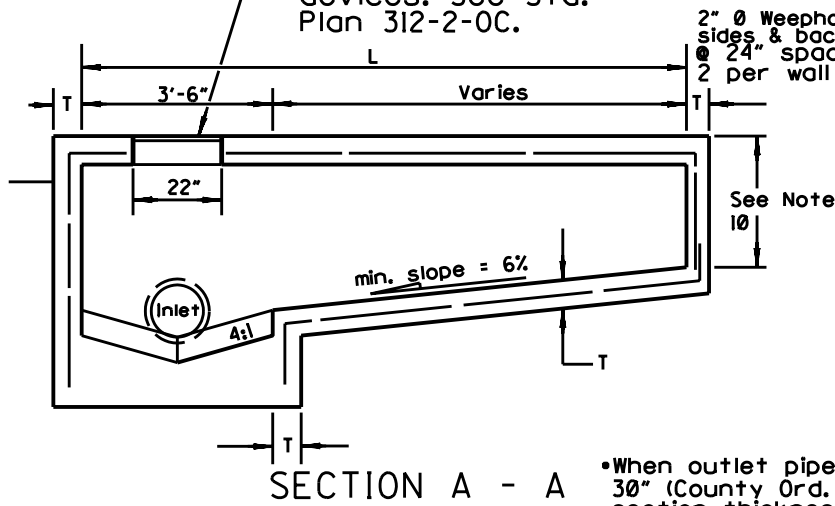

SECTION A - A

See Std. Plan  
1306 for Curb  
Support details.

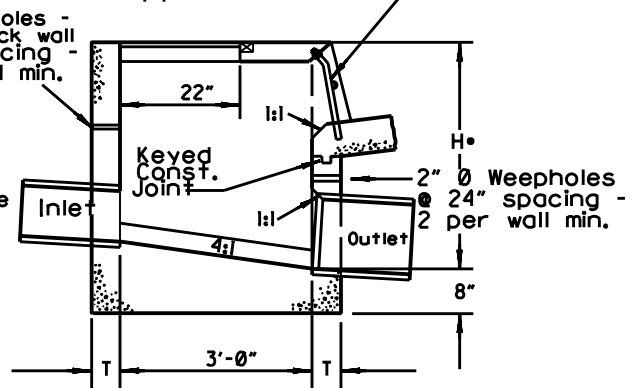

SECTION B - B

•When outlet pipe is constructed within roadway, a minimum of 30" (County Ord. No. 63.0322, 1961) or the roadway structural section thickness plus 6", whichever is greater, shall be maintained between the top of pipe and the roadway surface.

NOTES:

1. Standard opening lengths, "L" are 7', 10', 14' and 21'. Other lengths may be used, but not to exceed 21'.
2. All reinforcing is #4 @ 12" O.C. for H < 8' and #5 @ 12" O.C. for H ≥ 8' unless otherwise specified.
3. Curb opening shall conform to curb alignment.
4. See Std. Plans 1306 and 1307 for details and notes.
5. See Std. Plan 1308 for Local Depression details.
6. All steel shall be 2" clear from interior concrete surfaces.
7. T=6" for H=5'-0" to < 8"-0". T=8" for H=8'-0" to 20'-0".
8. The following shall be stencilled using 2 inch high letters and black point on the face of the curb adjacent to the inlet (either side) and on the top of the inlet:  

NO DUMPING  
DRAINS TO OCEAN
9. Deck, including steel reinforcement, shall be constructed the same width as sidewalk (up to 6' wide).
10. D = 3'-0" For L less than or equal to 10'-0". D = 4'-0" for L greater than 10'-0".

ORANGE COUNTY RESOURCES & DEVELOPMENT MANAGEMENT DEPARTMENT

Approved

*H. I. Nakasone*  
H. I. Nakasone, Chief Engineer

Adopted: Res. 77-92

Revised: Res. 78-791; 82-718; 86-1141; 91-1481; 96-546; 06-010; 07-048

STD. PLAN

1302

INLET TYPE II

SHT. 1 OF 1



## SECTION I. MATERIALS

(All references to "Standard Specification" in these Standard plans shall refer to the Standard Specifications for Public Works Construction (the Greenbook) unless otherwise specifically noted.)

Asphalt concrete (AC) shall meet the requirements of Section 400 of the Standard Specifications and these Special Provisions. Coarse aggregate shall consist of material of which at least 75% by mass shall be crushed particles in lieu of the requirements of Section 400-4.2.3, "Coarse Aggregate."

The performance grade of paving asphalt shall be PG 64-10 or as determined by the Engineer. Engineer shall mean the County of Orange Resources & Development Management Department (RDMD) Chief Engineer, or his authorized agent acting within the scope of his authority. Copies of test reports on paving grade asphalt, as defined by Section 203-1.3, "Test Reports and Certification," shall be available for each shipment.

Proposed Asphalt Concrete Job Mix Formula(s) shall be determined by Calif. Test Method #367, Method for Recommending Optimum Bitumen Content (Hveem Method). Job Mix Formulas and supporting California Test Method #367 test data shall be submitted to the RDMD Materials Engineer for approval annually in January unless otherwise approved by the RDMD Materials Laboratory. In no case shall the Job Mix Formula, and its supporting test data, be more than two years old. The aggregates used for determining the proposed Job Mix Formulas shall be from the same source as will be used in actual production. Changes in aggregate source or bitumen source or viscosity grade shall not be permitted unless a pre-approved Job Mix Formula for the changed aggregate or bitumen source(s) is on file with the RDMD. Submittals of all Job Mix Formulas for approval shall be made at least 20 days prior to intended use.

As a general guideline the required gradation for Orange County asphalt concrete mix designs will be as follows:

### ARTERIAL HIGHWAYS

- 3/4" (III-B-2) Base Course
- 1/2" (III-C-2) Surface Course
- 3/4" (III-B-3) Surface Course \*

### NON-ARTERIAL STREETS

- 3/4" (III-B-3) Base Course
- 1/2" (III-C-2) Surface Course

### BIKE TRAIL (OFF ROAD)

- 1/2" (III-C-3) Base and Surface Course
- 3/8" (III-D) Surface Course \*

### ASPHALT CONCRETE DIKES

- 3/8" (III-D-PG 64-10) Surface Course Mix

\* Use only when required by the Engineer.

ORANGE COUNTY RESOURCES & DEVELOPMENT MANAGEMENT DEPARTMENT

Approved

*H. I. Nakasone*  
H. I. Nakasone, Chief Engineer

Adopted: Res. 77-92

Revised: Res. 78-791; 82-718; 91-1481; 96-546; 04-095; 06-010; 07-048

STD. PLAN

1805

SHT. 1 OF 5

SPECIAL PROVISIONS - ASPHALT CONCRETE

Asphalt Concrete load tickets shall clearly show the mix designation for the approved Job Mix Formula.

The gradation for the project Asphalt Concrete Job Mix Formula shall be within the specification range as set forth in Section 400-4," ASPHALT CONCRETE" and TABLE 400-4.3 (C) "TYPE III ASPHALT CONCRETE." Deviations from the approved percentage passing each applicable Job Mix Formula sieve size shall be limited to following and in no case shall the sum of the absolute values of the deviations exceed 15:

ACCEPTABLE DEVIATION FROM JOB MIX FORMULA

Sieve	Acceptable Deviation
1"	±3%
3/4 "	±5%
3/8 "	±6%
No. 4	±6%
No. 8	±5%
No. 30	±5%
No. 200	±3%

Delete the third paragraph of Section 203.6.6.1, "General," and add the following: The binder ratio, pounds of binder per 100 pounds of dry aggregate shall not vary by more than 0.4 above or below the target binder ratio (Optimum Bitumen Content) in the approved mix design.

Asphalt Concrete suppliers shall maintain records of each aggregate and bitumen shipment received. Bitumen records shall include viscosity grade test data for AR grading. These records shall be maintained current and be readily accessible to the Engineer at the plant site upon request. The records shall include but not be limited to: aggregate or bitumen source of origin, location received and the date shipped.

The sand equivalent and Stabilometer-Value (S-Value) requirements of Section 400-4.3, "Combined Aggregates," shall be the moving average requirements. Individual test requirements for sand equivalent and S-value shall be as determined by the RDMD Materials Lab.

ORANGE COUNTY RESOURCES & DEVELOPMENT MANAGEMENT DEPARTMENT

Approved



H. I. Nakasone, Chief Engineer

Adopted: Res. 77-92

Revised: Res. 78-791; 82-718; 91-1481; 96-546; 04-095; 06-010; 07-048

STD. PLAN

1805

SPECIAL PROVISIONS - ASPHALT CONCRETE

SHT. 2 OF 5

## SECTION II. GENERAL PROVISIONS

Add to Section 302-5.1, "General," the following: The combined aggregate grading for asphalt concrete placed on miscellaneous areas shall conform to the gradation for the asphalt concrete placed on the traveled way, unless otherwise directed by the Engineer. The amount of asphalt binder used in the asphalt concrete placed in gutter, gutter flares, overside drains, and aprons at the ends of drainage structures, unless otherwise directed by the Engineer, shall be increased one percent by mass of the aggregate over the amount of asphalt binder used in the asphalt concrete placed on the traveled way.

The asphalt concrete to be place in areas which are designated on the plans as miscellaneous areas may be spread in one layer. The material shall be compacted to the required lines, grades and cross-sections.

Dikes shall be shaped and compacted with an extrusion machine or other equipment capable of shaping and compacting the material to the required cross-sections.

In advance of placing asphalt concrete dike on asphalt surfacing, the surface shall be broomed clean of all loose and extraneous material and a tack coat shall be applied.

If the finished surface of the asphalt concrete on the traffic lanes does not meet the specified surface tolerances, it shall be brought within tolerances by either: (1) abrasive grinding and grooving (followed by fog seal on the areas which have been ground), (2) placing an overlay of asphalt concrete, or (3) removal and replacement. The method shall be selected by the Engineer.

Delete Section 302-5.3, "Prime Coat," and substitute the following: When specified or required by the Engineer, a prime coat consisting of Grade SC-70 or SC-250 liquid asphalt shall be applied to the surface of the prepared base or subbase prior to placing asphalt concrete at the rate between 0.10 and 0.25 gallon per square yard.

Modify Section 302-5.4, "Tack Coat" as follows: A tack coat of SS-1h type emulsified asphalt, where stipulated on the plans and specifications or required by the Engineer, shall be applied in accordance with Section 302-5.4. Paving Asphalt may be used only when approved by the Engineer. Paving asphalt when, approved, shall be spread in accordance with previsions of Section 203-1, "Paving Asphalt."

Add to Section 302-5.5, "Distribution and Spreading," the following: Tarpaulins shall be used to cover all loads, when directed by the Engineer.

Unless otherwise permitted by the Engineer, the top layer of asphalt concrete for shoulders, tapers, transitions, road connections, private drives, curve widenings, turnouts left turn pockets and other such areas, shall not be spread before the top layer of asphalt concrete for the adjoining through lane has been spread and compacted. At locations where the number of lanes is changed, the top layer for the

ORANGE COUNTY RESOURCES & DEVELOPMENT MANAGEMENT DEPARTMENT

Approved

*H. I. Nakasone*  
H. I. Nakasone, Chief Engineer

Adopted: Res. 77-92

Revised: Res. 78-791; 82-718; 91-1481; 96-546; 04-095; 06-010; 07-048

STD. PLAN

1805

SHT. 3 OF 5

SPECIAL PROVISIONS - ASPHALT CONCRETE

through lane shall be paved first. Tracks or wheels of spreading equipment shall not be operated on the top layer of asphalt concrete in any area until final compaction has been completed or unless directed by the Engineer.

Unless otherwise specified in the approved Pavement Design Report, the top layer of asphalt concrete shall not exceed 0.20-foot in compacted thickness. Each lane of the top layer, once commenced, shall be placed without interruption.

Unless specifically provided for in the Special Provisions, bottom dumps shall not be used in the paving operation for top layer paving of asphalt concrete on arterial highways.

All screed extensions for paving machines shall be provided with a tamper, roller or other suitable compacting devices.

Unless otherwise approved by the Engineer, the paving machines shall have a suitable operational joint compacting device in place and use when placing the top layer of asphalt concrete on arterial highways.

Add to Section 302-5.6, "Rolling," the following: Three-wheeled rollers as specified in Section 302-5.6.1 "General," shall not be permitted. Pneumatic rollers shall be required on lower layers only. Pneumatic rollers may be used for intermediate rolling on finish course paving for Arterial Highways with the approval of the Engineer.

Rolling for compaction of asphalt concrete shall not be permitted after the temperature of the mat surface falls below 160°F. Intermediate rolling of the finish course paving with a pneumatic roller shall not be permitted after the temperature of the mat surface falls below 175°F.

For subdivision and permit work within the County, the final or surface layer of the asphalt concrete shall not be placed until all on-site improvements have been completed, including all grading and until all unacceptable concrete is removed and replaced at the direction of the Engineer.

All manhole, valve and vault covers shall be finished 1/4 " below finished grade.

When specified or directed by the Engineer, a fog seal of SS-1h or CSS-1h type emulsified asphalt shall be applied to the finished surface of asphalt concrete pavement at a rate of 0.05 to 0.10 gallon per square yard as determined by the Engineer. Additional water shall be added to the material and mixed therewith in such a proportion that the resulting mixture will contain not more than 50% of the added water, the exact quantity of added water shall be determined by the Engineer. The rate of application of the resulting mixture shall be that the undiluted emulsion will be spread at the specified rate. Prior to placement of the fog seal, all dirt, mud, trash, or other loose material shall be cleaned from the area to be covered. All asphalt concrete paving in local and private streets shall require a fog seal.

ORANGE COUNTY RESOURCES & DEVELOPMENT MANAGEMENT DEPARTMENT

Approved



H. I. Nakasone, Chief Engineer

Adopted: Res. 77-92

Revised: Res. 78-791; 82-718; 91-1481; 96-546; 04-095; 06-010; 07-048

STD. PLAN

1805

SPECIAL PROVISIONS - ASPHALT CONCRETE

SHT. 4 OF 5

### SECTION III. DEEP LIFT PAVING

In addition to the provisions of Sections I and II for asphalt concrete pavement, the following provisions shall be adhered to when constructing asphalt concrete pavement, deep lift section, where shown on the plans or specified by the Engineer.

Asphalt concrete base shall be spread at a temperature of not less than 230°F nor more than 300°F unless a higher temperature is ordered by the Engineer and shall be spread and compacted in layers not to exceed 0.50-foot in compacted thickness. When more than one layer of base course is required, the layers shall be of equal thickness. The following shall apply to spreading:

1. Each layer shall be spread with an approved spreading device which will deposit a uniform layer for minimum of one traffic lane width. A motor grader shall not be used as the spreading device.
2. The minimum temperature of asphalt concrete for completion of the initial breakdown compaction shall be 225°F.
3. Initial or breakdown compaction shall be performed with two-or-three-axle tandem roller with a mass of no less than 12 tons.
4. For County-funded construction contracts, the initial or breakdown rolling shall be immediately followed by a motor grader with additional material to level irregularities and provide a uniform surface for subsequent layers. Additional rolling shall proceed directly behind the motor graders with a pneumatic-tired roller while the temperature of the asphalt concrete is above 180°F.
5. For subdivision and permit work within the County, when three or more courses are required, depths of the next course shall be painted for the top two courses at intervals not to exceed 50 feet as directed by the Engineer.
6. The subsequent layers of asphalt concrete shall not be spread when the underlying layer is above 150°F.

### SECTION IV. BIKE TRAIL PAVING

The amount of asphalt binder used in the asphalt concrete placed for Off Road Bike Trail Paving shall be increased one percent by mass of the aggregate over the amount of the asphalt binder used in the asphalt concrete if placed as roadway paving. • Asphalt concrete pavement for the bike trail may be placed in one lift by a self-propelled machine. All other provisions of Section I and II shall apply.

- S-Value requirements will be determined by the RDMD Materials Engineer.

### SECTION V. RUBBERIZED ASPHALT GAP GRADED MIXES

Proposed Job Mix Formulas shall be established by Calif. Test Method \*367, Method for Recommending Optimum Bitumen Content (Hveem Method) as set forth in SECTION I herein. Aggregate gradations, binder and rubber content shall be as generally set forth in the Standard Specifications.

ORANGE COUNTY RESOURCES & DEVELOPMENT MANAGEMENT DEPARTMENT

Approved

  
H. I. Nakasone, Chief Engineer

Adopted: Res. 77-92

Revised: Res. 78-791; 82-718; 91-1481; 96-546; 04-095; 06-010; 07-048

STD. PLAN

1805

SPECIAL PROVISIONS - ASPHALT CONCRETE

SHT. 5 OF 5

## SECTION I. STRUCTURAL EXCAVATION AND BACKFILL

(All references to "Standard Specifications" in these Standard Plans shall refer to the Standard Specifications for Public Works Construction (the Greenbook) unless otherwise specifically noted.)

Delete the third paragraph in Section 300-3.3, "Foundation Material Treatment" of the Standard Specifications, beginning "Where the original..." and substitute the following:

Relative compaction of not less than 95% shall be obtained for embankment under bridge and retaining wall footings without pile foundations within the limits established by inclined planes sloping 1.5 Horizontal to 1 Vertical out and down from lines one foot outside the bottom edges of the footing:

Add to Section 300-3.5, "Structural Backfill," the following paragraphs:

Backfill at bridge abutments shall have a relative compaction requirement of not less than 95%.

Compaction equipment or methods which may cause excessive displacement or may damage structures, such as sleeve tampers (stompers), shall not be used.

All excavation and backfill of reinforced concrete box conduit shall conform to Section 300-3.1, Structure Excavation and Backfill, General, of the "Standard" Specifications.

Delete last sentence of paragraph one in Section 300-3.1, "Excavation and backfill for underground conduit..." and substitute the following:

Excavation and backfill for underground conduit construction shall be in accordance with Section 306.

## SECTION II. SUBGRADE TOLERANCES

Section 301-1.4, "Subgrade Tolerances," shall be deleted, and the following shall be added:

Subgrade for pavement, sidewalk, curb and gutter, driveways, or other roadway structures shall not vary more than 0.05 foot from the specified grade and cross section. Subgrade for subbase or base materials shall not vary more than 0.10 foot from the specified grade and cross section. Variations within the above-specified tolerances shall be compensating so that the average grade and cross-section specified are met.

ORANGE COUNTY RESOURCES & DEVELOPMENT MANAGEMENT DEPARTMENT

Approved

  
H. I. Nakasone, Chief Engineer

Adopted: Res.

Revised: Res. 04-095; 06-010; 07-048

STD. PLAN

1806

SPECIAL PROVISIONS - EARTHWORK

SHT. I OF I